

Galvanised Liquistore[®] / Firestore[®]



For standard fire sprinkler water storage applications or general industrial water storage requirements, the Liquistore[®] / Firestore[®] tank is a cost effective solution.

Using site assembled components, consisting of overlapped and bolted galvanised steel panels with either a trough deck or aluminium sectional site assembled cover, together with an internal, open top membrane liner, the Liquistore[®]/Firestore[®] offers a truly long life and low maintenance water storage system.

Standard tanks are available in capacities from 10m³ (2,200 UK gallons) to 2,222m³ (488,840 UK gallons) and in diameters from 3.06m to 21.40m and heights from 1.25m to 13.26m. Non standard and larger size tanks are available upon request.

Firestore[®] tanks are approved by the UK Loss Prevention Certification Board for storage of fire sprinkler water and by the UK Water Regulations Advisory Scheme for the storage of potable water under the name Liquistore[®].

Ease and speed of assembly. No sealants are used on the tank shell. This means that site installation can make full use of hydraulic jacking with the confidence in knowing that the integrity of the tank is not reliant on a large number of individual panel seals.

Simplicity of foundations. All that is required to site the tank is a flat load bearing surface, typically of reinforced concrete. The bottom rolled angle at the tank base is simply bolted to the concrete floor.

Low maintenance. The galvanised steel panels to the tank are made from high quality pre-galvanised strip to BS2989 Grade Z35, with a zinc coating of 300g/m² each side of the panel. For plate thicknesses above 4.2mm, each plate is hot dip galvanised to the requirements of BS EN ISO 1461 (1999). This means a highly corrosion resistant exterior finish to the tank. Internally the hot vulcanised, tailor-made membrane liner separates the stored water from the tank shell, often a major cause of corrosion. The membrane liner itself will not rot or deteriorate in the same way that other coatings and finishes to the interior of tanks will.

Galvanised Liquistore®/Firestore® Technical Data

- Capacities** From 10m³ to 2,222m³ in standard sizes. Larger capacities are available upon request. Maximum 1,300m³ for UK LPC approval.
- Dimensions** From 3.06m to 21.39m in diameter, maximum height is dependent upon diameter. At 21.39m diameter maximum height is 6.33m. Larger diameters available upon request.
- Ancillaries/Accessories** A wide range of extra equipment and fittings are available, including: Ball float valves, high/low level switches, internal ladders, sump liners, fire brigade couplings, low level manways. Standard accessories include: Immersion heater, anti-vortex device, contents gauge, external ladder and landing, WRc Type 'AB' airgap.
- Foundations** All that is required is a flat load bearing slab. A suggested layout for each of our standard tank dimensions is available on request. Foundation loading is based upon the rim height of the tank multiplied by 9.81 = kN/m². Level tolerance should be +/- 6.0mm across base.

Typical 135m³ Firestore® Fire Sprinkler water storage tank. 6.11m diameter x 5.142m high.

Elevation

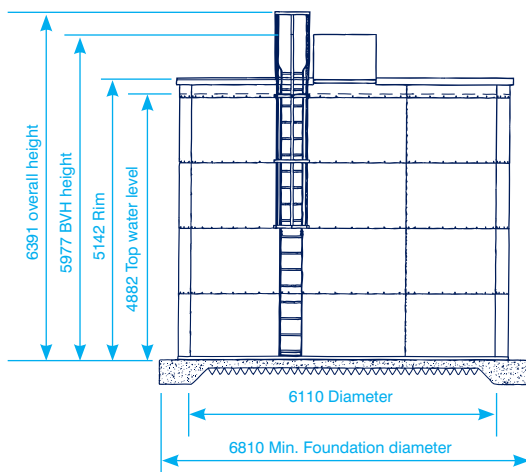

Plan

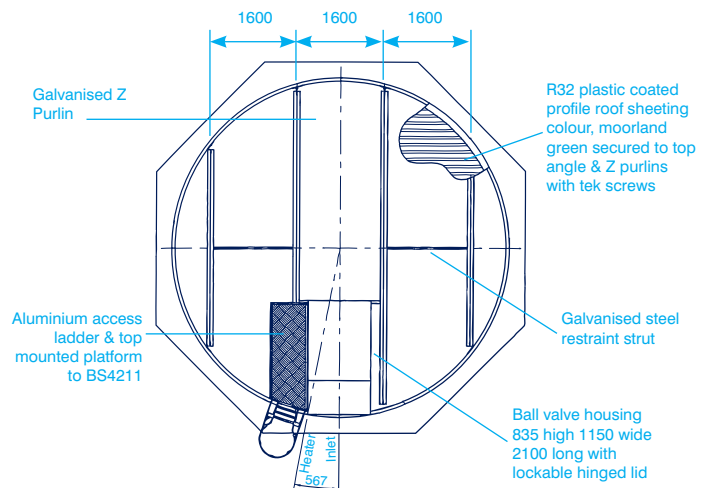

Typical connection through tank wall

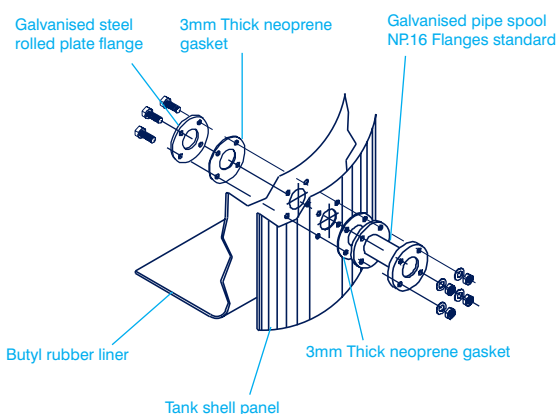

Franklin Hodge Industries Ltd
Jubilee Building, Westfields Trading Estate
Faraday Road, Hereford HR4 9NS
Telephone: +44 (0) 1432 269605
Fax: +44 (0) 1432 277454
Web: www.franklinhodge.com